

EUREKA

ASSEMBLY INSTRUCTION MANUAL



We must stress, that all components supplied by *EUREKA*, meet with the current ADR's and that you should build your car in strict accordance with our Assembly Manual Instructions, using only the components supplied by and available from *EUREKA SPORTS CARS*, 23 Stephen Road DANDENONG VIC 3175.
Telephone: 03 793 1000; : 03 794 6828.



EUREKA SPORTS CARS & FIBREGLASS PRODUCTS



THE SPORTS CAR FOR THE INDIVIDUAL

23 Stephen Road, Dandenong, Vic. 3175

MOBILE PHONE No.
018-392 864
BUSINESS HOURS

CONTENTS:

1. Introduction
2. Forward
3. Where to look for a VW
- 4/5. Things to Save or Do/Drawing
- 6/7. Removal of the VW Body
8. Petrol Tank
9. Fire Wall and P/T Support
- 10/11. Construction of the Car/Drawing
12. Noise Reduction Box
13. Rear Suspension Mounts
14. Under Front Bonnet
15. Roof Lifting Gear Assembly
16. Dash Pod and Console
17. Steering Column
- 18/19. Ducting and Heater Installation
- 20-23. Fitting of Lower Panels
- 24-26. Seats/Seat Belts
27. Roof Sealing Rubber
- 28/29. Wiring - Interior Headlight Assembly - Steel Chanel
- 31/33. Parts Check List.
34. Guide to Sequence of Building

In 1974 a new GT car, the *EUREKA* was introduced. Two years of development and preparation had resulted in the completion of a truly unique road car. Already in production for two years in England and then released in the USA the car had and is still receiving a fantastic reception. (The English car being the *NOVA*, USA the *STERLING*.)

Design work by Richard Oakes and engineering by Phil Sayers in England had combined to produce stunning looks yet functional behaviour. Incorporating mechanical components of the Volkswagon, the *EUREKA* heralded a significant step forward for this breed of vehicle, the accent being on safety.

Beautiful lines and well planned interior constitute the cars immediate attraction, while closer inspection will reveal an extremely high standard of finish achieved on the fibreglass body. This is largely due to the use of the same techniques involved in building a power boat hull, principally the use of "Woven Rovin" woven strand fibreglass, which gives extremely high tensile and comprehensive strength. In places the body strength is up to 5/16" thick and truly rigid. Passenger protection, a subject causing much consternation has been attended to by providing seven inch wide box sections along the body sides and a similar construction at the nose, completed here by the spare wheel backed up against a fibreglass wall which also provides the two most forward chassis mounting points.

Two inherent faults in the use of the Volkswagon chassis through past designs have been the amount of flex found with fibreglass bodies that have only been bolted to the chassis at the standard points. To overcome this problem, the *EUREKA* has additional body mounting bolts, two each at both the front and rear suspension points.

FORWARD

Congratulations, you have just become a member of a very elite group of individuals. Those who purchased and are willing to step forward, take tools in hand and complete the finest component car made in Australia ... the *EUREKA*.

These instructions were specifically developed to assist you in the completion of your *EUREKA*. Based on our experience and those of our customers, the steps shown seem to be the most efficient.

It is most important that you read through these instructions from cover to cover prior to any assembly so that you might familiarise yourself with the basic steps. During assembly it is recommended that you refer to these instructions often to eliminate doing things incorrectly or out of sequence.

The quality of the finished product is in your hands. Remember, anything worth doing is worth doing right. Take your time, do not rush, give it some attention to detail and you will be proud to ... OWN AND DRIVE A "EUREKA"!

These instructions cover the construction of a standard *EUREKA* (we have never seen a standard *EUREKA*). Most *EUREKA* owners have done certain little touches to their cars, ie, special bumpers, mild to wild paint jobs or striping, air conditioning, extra upholstery, etc. It is our hope that no two *EUREKA'S* be exactly alike so go ahead, put a little of yourself into your *EUREKA*. After all, isn't that what it is all about? If we can assist you with information on some of your ideas, just let us know.

The feeling you get while driving a *EUREKA* is unlike anything achieved while driving any other type of automobile. Funny things happen like being given preferred parking at night clubs, restaurants, at the golf clubhouse, etc. Strangers have a way of becoming friendly almost on sight. It is really difficult to describe because it is a feeling that only comes with the ownership of a truly personal automobile.

We, at *EUREKA SPORTS CARS* are looking forward to adding your name to the growing list of people who drive a *EUREKA*.

In closing, we would appreciate a photo of you and your car upon its completion. It is of extreme value to us for our log of owners.

OWNING A *EUREKA* IS NOT LIKE OWNING A CAR. IT IS LIKE BEING PART OF AN EXCLUSIVE CLUB. WELCOME TO THE CLUB!

WHERE TO LOOK FOR A VOLKSWAGON

- Foreign car repair shops. May have one that needs work or may know of one for sale.
- Dealers or used car lots. May have one that is a bit rough or with several smashed fenders at a reasonable price.
- Wrecking yards. May have one with blown engine or roll over, etc.
- Check with local insurance companies for wrecked volkswagons. Be sure to check for severe damage to chassis. (Particularly front end suspension damage.)
- Put an advertisement in the paper or on bulletin board of local supermarket.
- Trading Post or Auto magazines.

It goes without saying that the newer the volkswagon, the newer your *EUREKA*.

THINGS TO SAVE OR DO

1. Fuel tank.
 2. Clamps for tank (4) bolts for tank (4).
 3. Bolts for rear body bracket (2). Washers for same (2).
 4. Front body mounting bolts (2). Rubber spacers (4). Steel washers, Chanel type (2).
 5. Steering column (collapsible must be used), horn wire, rubber coupling, column to dash bracket and rubber grommet through body.

Using a late model, column has convenient switches on arms such as, wiper switch, head light high beam and flasher washer, etc.
 6. Jacking points. Remove both sides (hacksaw).
 7. Bend clutch pedal approximately one inch to the left, away from steering column. Easily done using twelve inch crescent wrench and screwdriver.
 8. Detail drawing of side rail on floor pan.
 9. Trans-axle inspection plate, remove and discard. This allows replacement of trans-axle at a later date.
 10. Master cylinder reservoir and hoses.
 11. Rubber gasket between floor pan and body (you may wish to install a new one).
 12. Steel body washers. Use these in the same position on *EUREKA* body, in combination with bolts and further steel washers supplied.
 13. Regulator box.
- NB. In addition to above, you may wish to save the windshield washer components and any other accessories your bug may have.

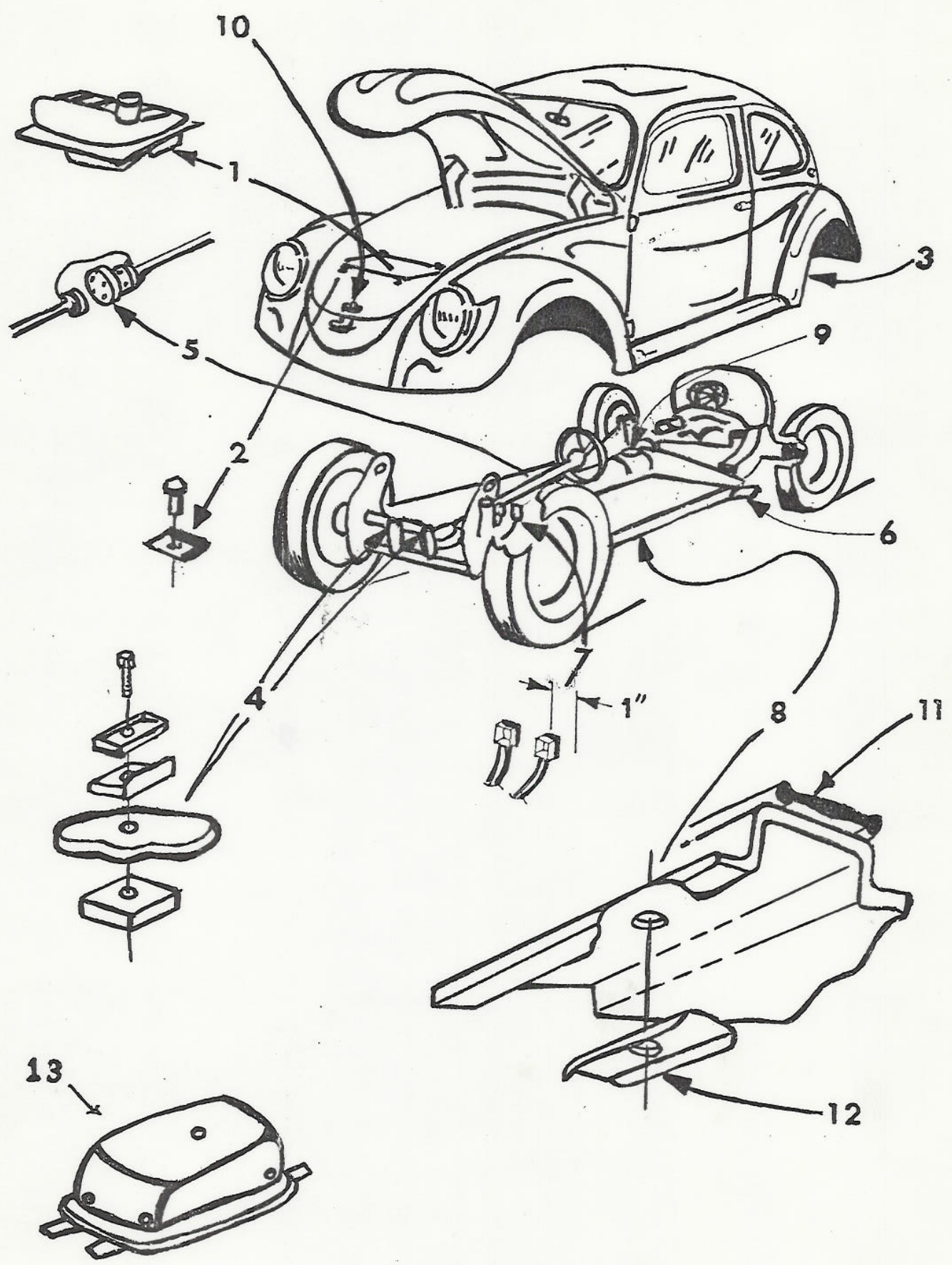

REMOVAL OF THE VOLKSWAGON BODY

This section applies to the Type 1 Volkswagon Beetle 1968 through to 1976.

You may want to snap a couple of pictures of the old VW as you are about to create an entirely new and different type of machine ... both in appearance and performance. The before and after photo make for interesting conversation when you have completed your *EUREKA*.

Many of the items that are not used from the VW may still be in good condition. They may be salable to your friends, local body shops or to auto salvage yards, so do not overlook the value of parts left over. Some of the parts are to be used in the "Things to Save" list.

Because of slight variations between VW's construction from year to year and the changes or modifications that may have been made, the exact location of some of the equipment to be removed may vary. This is why a final check should be made before attempting to lift the body from the chassis.

REMOVE THE GAS TANK

Remove four bolts and clip washers located around flange of gas tank (save these clip washers). Raise the tank and disconnect fuel line and drain all gasoline into a container. Remove gas tank (save the gas tank) and store in safe place with gas cap removed to prevent accumulation of fumes. It is recommended that the above mentioned operation be done in a well ventilated work area. (Tap tank at lowest point with screwdriver to check for rust.)

REMOVE STEERING COLUMN

Disconnect rubber coupling on steering box side by removing two bolts (label and save horn wire). NB. Rubber coupling should be replaced prior to assembly of *EUREKA*. It is inexpensive and for safety reasons it should be done.

Remove steering column clamp at dash and pull steering column through body and into car. NB. Save clamp and rubber gasket or bushing around steering column at exit hole through body.

REMOVE FRONT BODY BOLTS (TWO)

These two bolts are now visible through opening formerly occupied by gas tank (save these bolts, washers and rubber spacers).

REMOVE BRAKE CYLINDER RESERVOIR

Disconnect fluid line and drain into container; old fluid is to be discarded. (Save hoses and reservoir.)

SPEEDO CABLE REMOVAL

Remove spring clip in centre of left front axle hub. Pull cable out from back side then disconnect from speedometer. (Save cable.)

REMOVE ALL FLOOR PAN BOLTS

From along perimeter of floor pan including those found under rear seat (save special VW channel shaped washers for floor pan bolts). If you miss any bolts, you will find it difficult to remove body.

REMOVE - DISCONNECTION OF PARTS IN THE ENGINE COMPARTMENT

Disconnect throttle cable, manual choke cable or wire to automatic choke. Disconnect coil, voltage regulator, oil pressure sender unit.

DISCONNECTING PARTS FROM UNDER REAR OF VW

Jack-up rear of VW and remove rear wheels, exposing rear body brackets (one each side). Remove large bolt and washer where bracket mount to rear shock towers (save bolts and washers). Disconnect heater hoses from heater boxes. Replace wheels and drop VW back on floor.

REMOVAL OF BODY FROM CHASSIS

Break the body loose from the chassis by lifting at the centre of each wheel opening - one at a time - moving from one opening to the next. When all corners are free, ram a four inch by four inch block of wood between body and floor pan at each corner. Now you can visually check to see if anything is still connected, check for miscellaneous wires, etc. If any, they can be disconnected or cut, because a complete wire harness is standard equipment with your *EUREKA*.

Assuming that everything is now disconnected, it is now time to call upon four or five of your friends to assist you in lifting the VW body from the chassis.

Having completed the above steps, you have a stripped chassis to get prepared for your *EUREKA* and a body and miscellaneous other parts to sell, trade or haul away. Preparation of the chassis is covered under section titles "Construction of Car".

PETROL TANK:

1. Original square V.W. petrol tank washers.
2. Angle brackets.
3. Petrol tank.

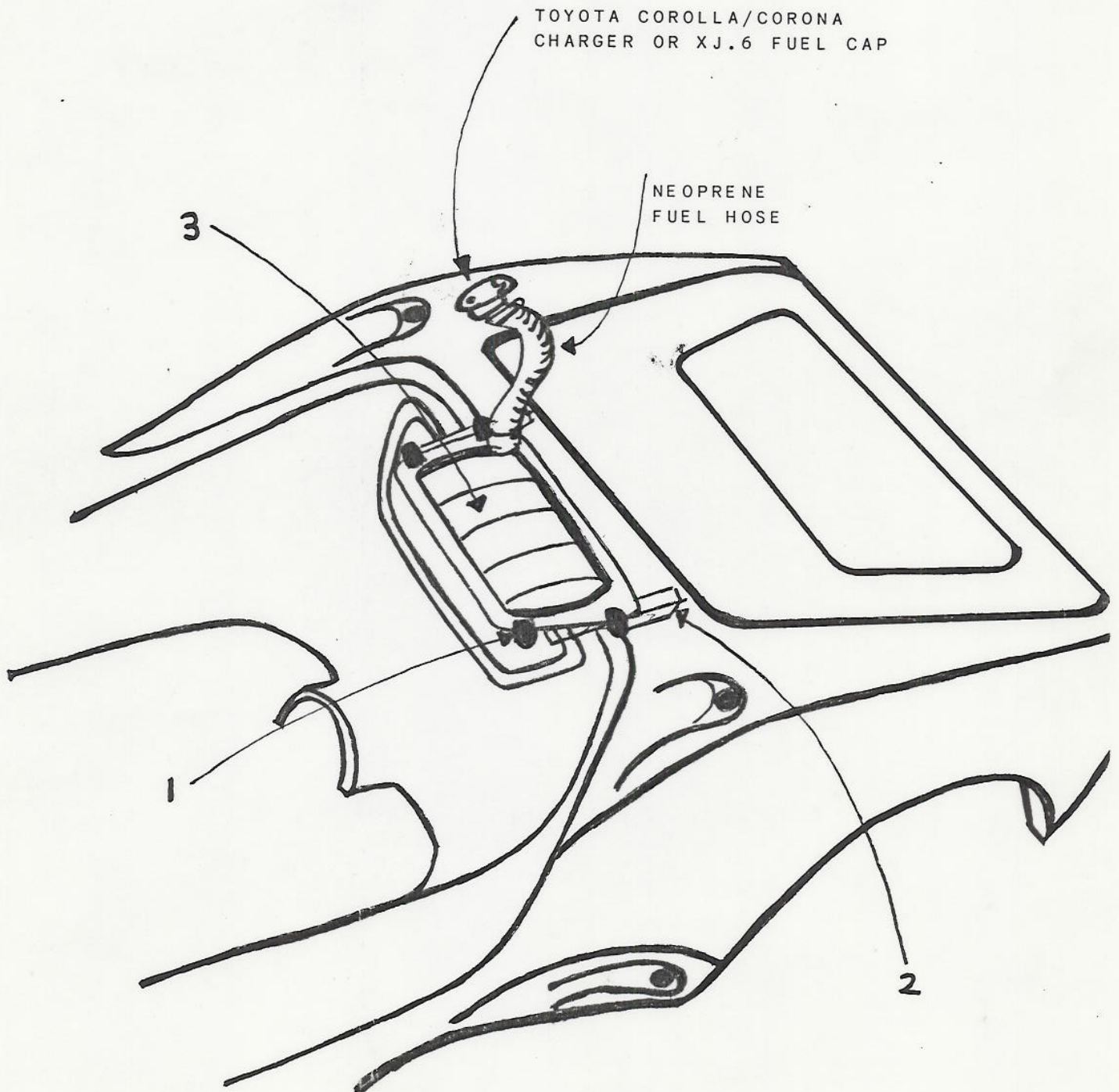

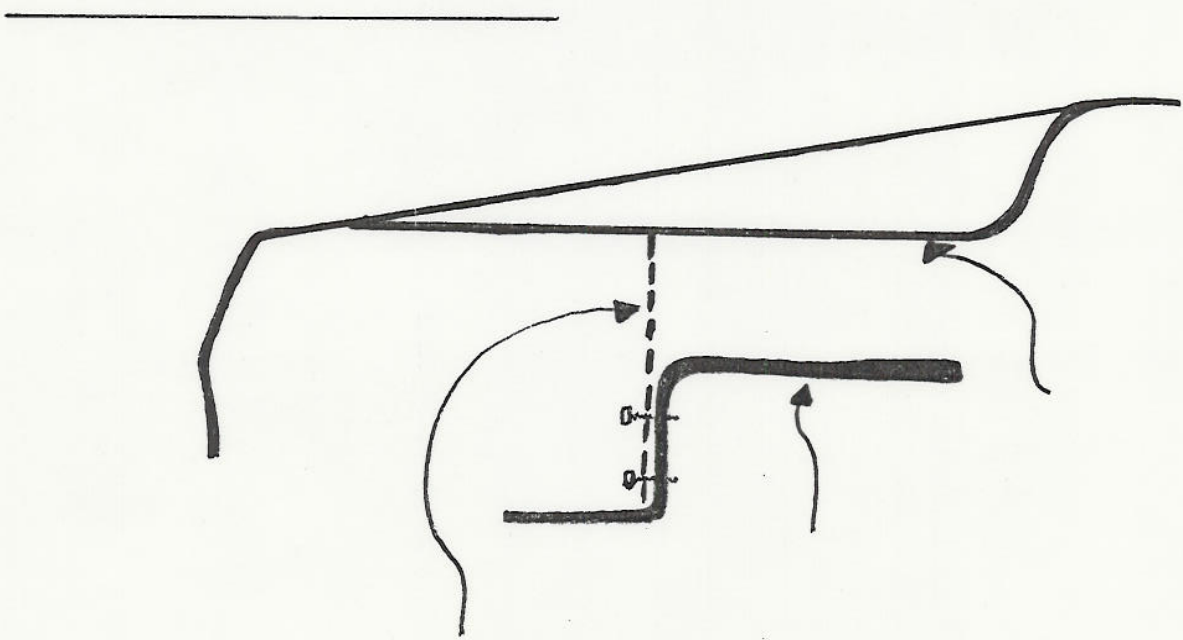
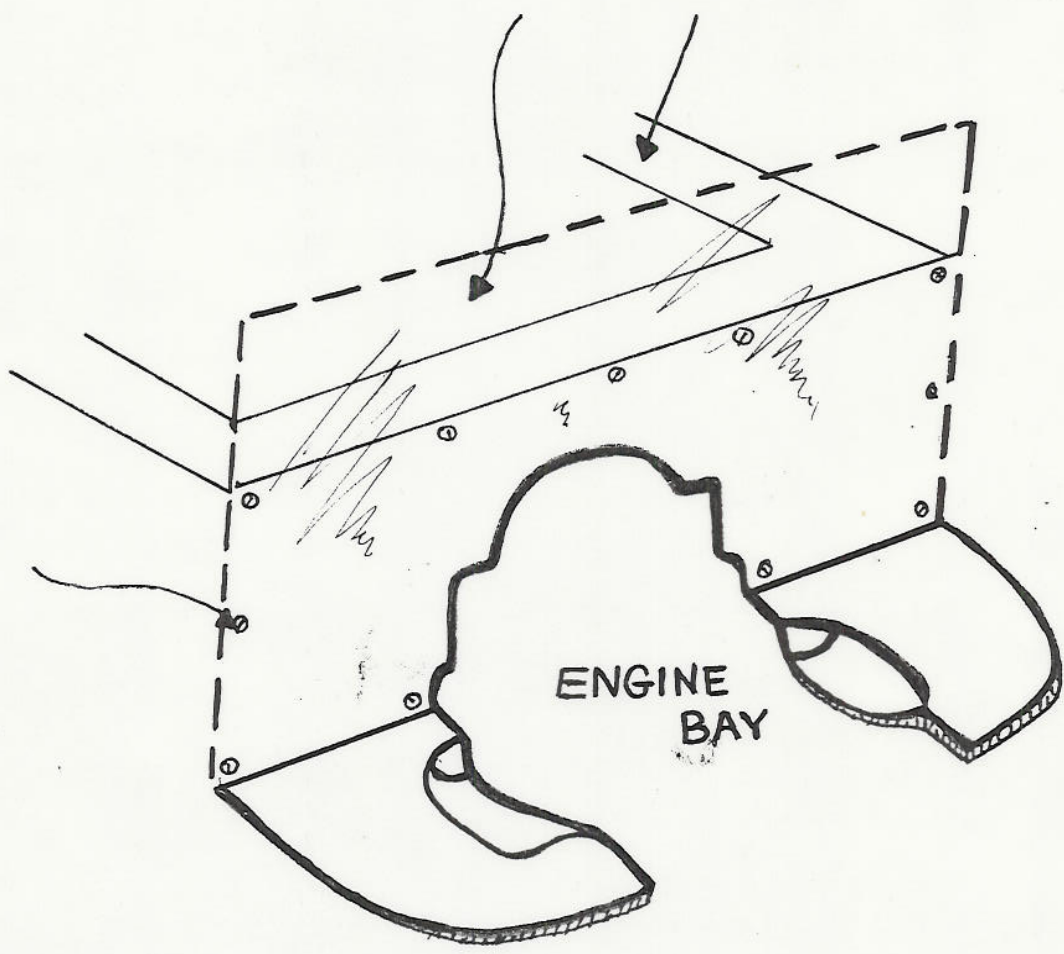

CONSTRUCTION OF THE CAR

1. Removing the VW body and saving miscellaneous parts.
2. CHASSIS PREPARATION

After removing the VW body from the floor pan and saving the necessary parts, clean the pan thoroughly using a sanding disc for stubborn rust, should there be any. A coat of killrust primer and then a coat of killrust paint at this stage will give the pan a tidier appearance and protect it against future corrosion. Inspect all mechanical parts on the rolling chassis and replace if worn.

3. PETROL TANK

Petrol tank must be fitted before body is bolted to floor pan. Use the original square washers and 5/16 bolts and large washers. Use angle brackets at each side of the tank.

To provide protection of the fuel tank and filler pipe from the engine compartment you will be required to laminate into position a sheet of fireproof fibreglass or aluminium sheeting (see diagram on previous page).

4. FLOOR PAN

Secure the VW belly pan gasket around the perimeter of the floor pan bedding it down with some rubberised sealant, securing the curved areas with pop rivets. At the rear of the floorpan there is a small inspection cover which covers the gear linkage universal joint, discard this and reroute the rubber gasket around the front of the hole. Cut a three inch hole in fibreglass for inspection. Make sure that the chassis number is accessible.

5. FITTING THE BODY

Try the *EUREKA* body on the chassis for fit. If anything fouls or does not clear, make adjustments as follows:

With engine shrouding and engine - cut out some of the fibreglass shrouding using a sabre saw, file, etc. Check clearance around pedals up front. After you are sure that the body does indeed nestle down onto the chassis, making sure that two holes are drilled in front trunk compartment to allow shoulder of threaded mounting point on front top torque tube to stick through. Now take the body back off and prepare the VW chassis for final mating with *EUREKA* body as follows.

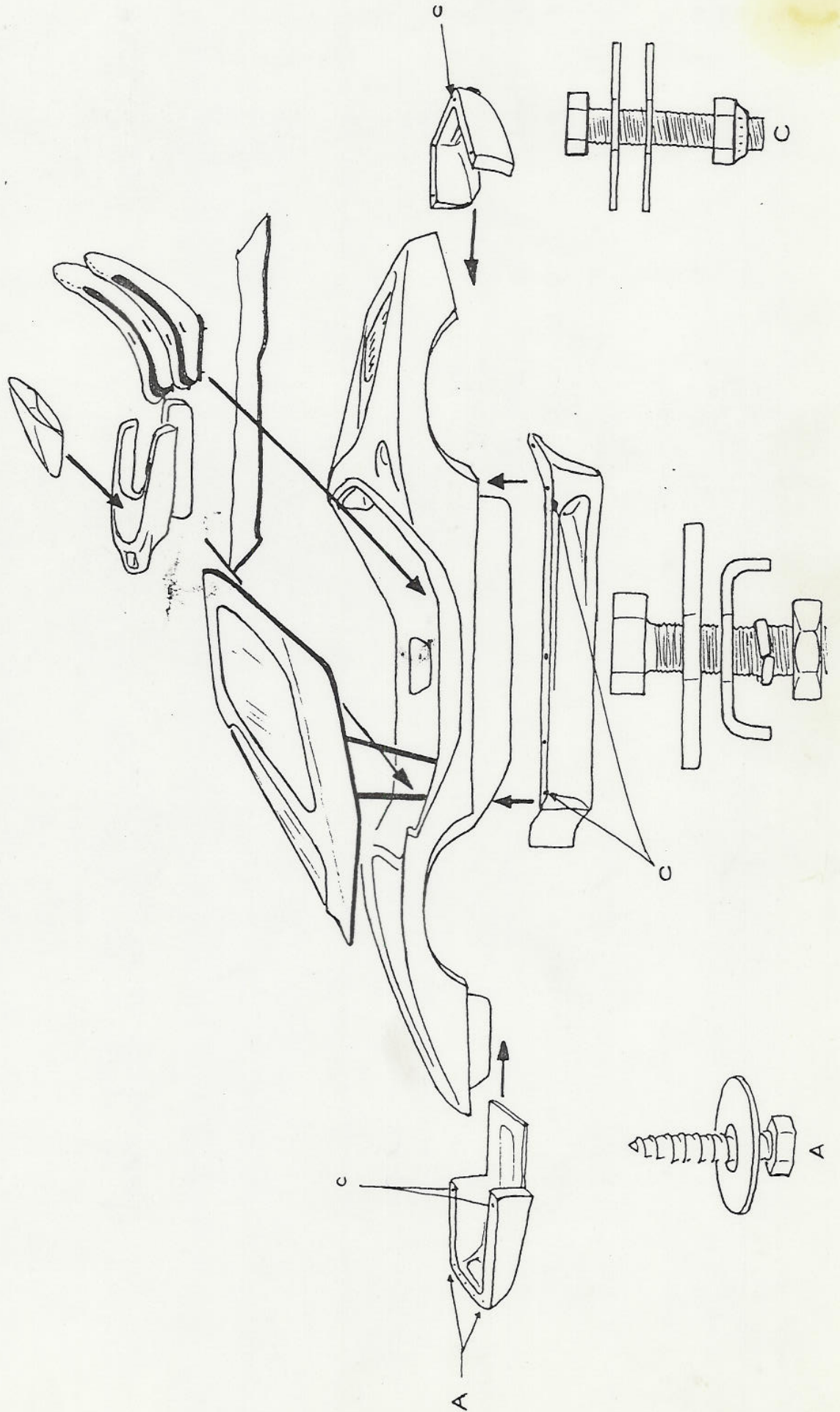

NOISE REDUCTION BOX

The noise reduction box is constructed of metal sheeting and fibreglass insulation bats. (Not supplied.)

1. Rear window opening access to petrol tank, sender unit and to form the noise reduction box.
2. Petrol tank.
3. Empty space to place fibreglass insulation in and around petrol tank.
4. Curved piece of sheeting to fit over the transaxle and screw to the side walls.
5. A flat sheet is fixed to the curved sheet to form a wall to block off the box.
6. Transaxle.
7. Fireproof wall.

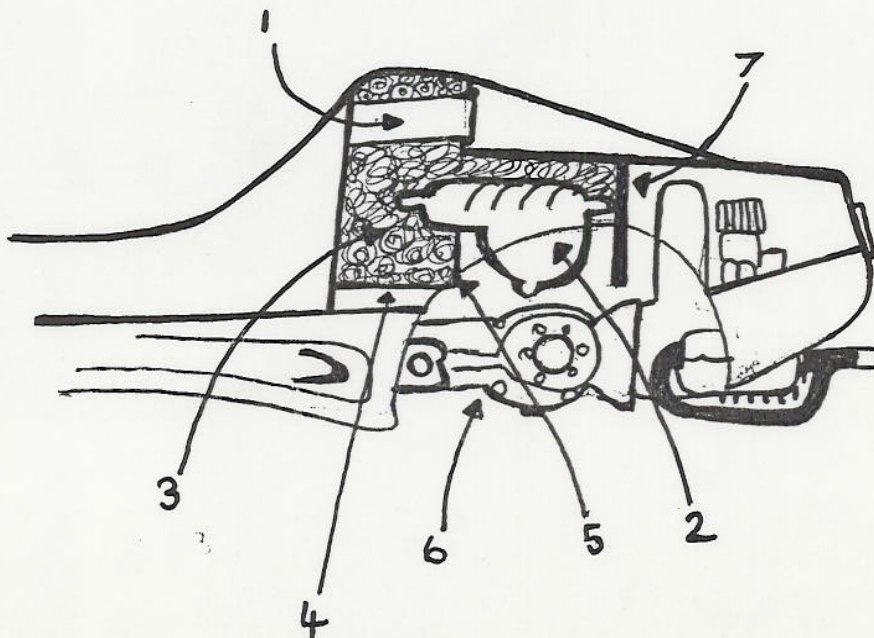

N.B.

Rear suspension Setting. (normally required on pre '69 swing arm chassis only)

First remove the shock absorber & and unscrew the three bolts which hold the trailing arm & the axle together. Unscrew the 4 bolts which locate & hold the trailing arm & torsion bar together. Pull off the end plate & rubber block, now pull the arm off the end of the torsion bar. This operation can be difficult for two reasons:
 a) because of possible corrosion between two parts and,
 b) because of the pre stress between the trailing arm and the torsion bar.

The best approach to this problem is to knock a cold chisel into the gap behind the trailing arm. A certain amount of caution must be used during this operation to avoid being struck by a "flying trailing arm". Slide torsion bar out and rotate arm upward approximately one to two splines giving approximately 1-2" drop in chassis height. More or less may be required due to varied strengths of torsion bar. re-assemble using reverse procedure. This allows rear suspension to work in its normal fashion with the lesser degree of body weight. Retains normal clearance.

1. You will have noticed that the floor pan has square corners and the EUREKA body is rounded. Fill gaps with instant foam (available from EUREKA) then apply silicone on foam & smooth.

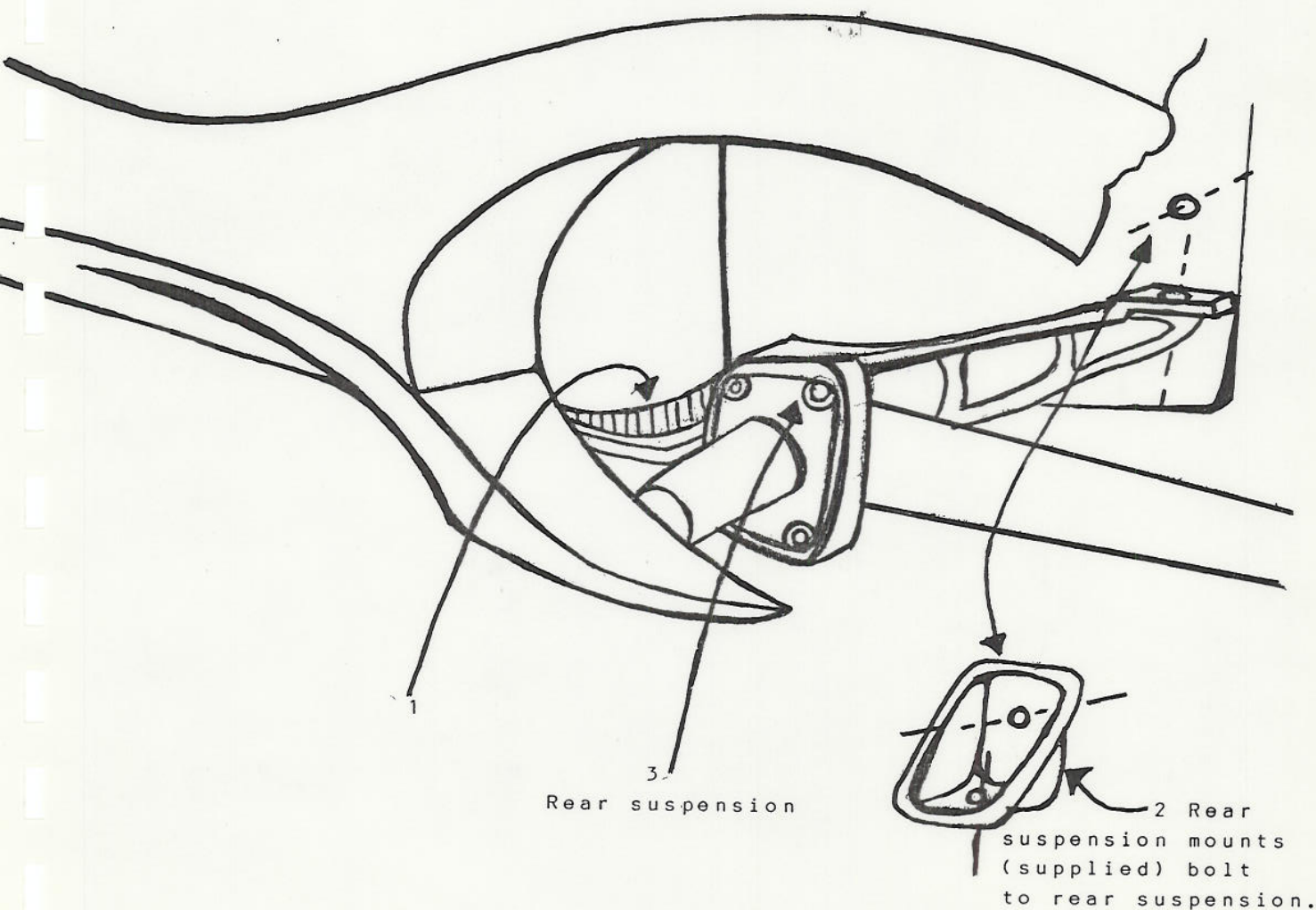

1. Location of holes for body mounting bolts into top of front suspension. (torque tube)
2. Opening provided for maintenance to steering box.
3. Master Cylinder reservoir: you will notice a trough or valley at this area. The reservoir wants to be placed here if it's an elongated rectangle type. (If it is square as in various year V.W.'s it wants to be placed on vertical wall just immediately rear of body mounting bolts as pointed out over #1 below. With front hood off, stand at front of car looking at two female receptacles for hood pins. The centre reservoir wants to be approximately 6" towards passenger side of car when measuring from centre of drivers side female receptacle. Approximately at centre of trough or valley, drill a $\frac{1}{4}$ " pilot hole & check alignment. Reservoir wants to be located as close to directly over Master Cylinder as possible. Now cut an opening $4\frac{1}{2}$ " by $1\frac{3}{4}$ " & file to fit so that reservoir fits snugly into opening with flange holding it from falling through. Secure with a strap across the top of reservoir.
4. Positive battery cable.
5. Windscreen washer bottle.

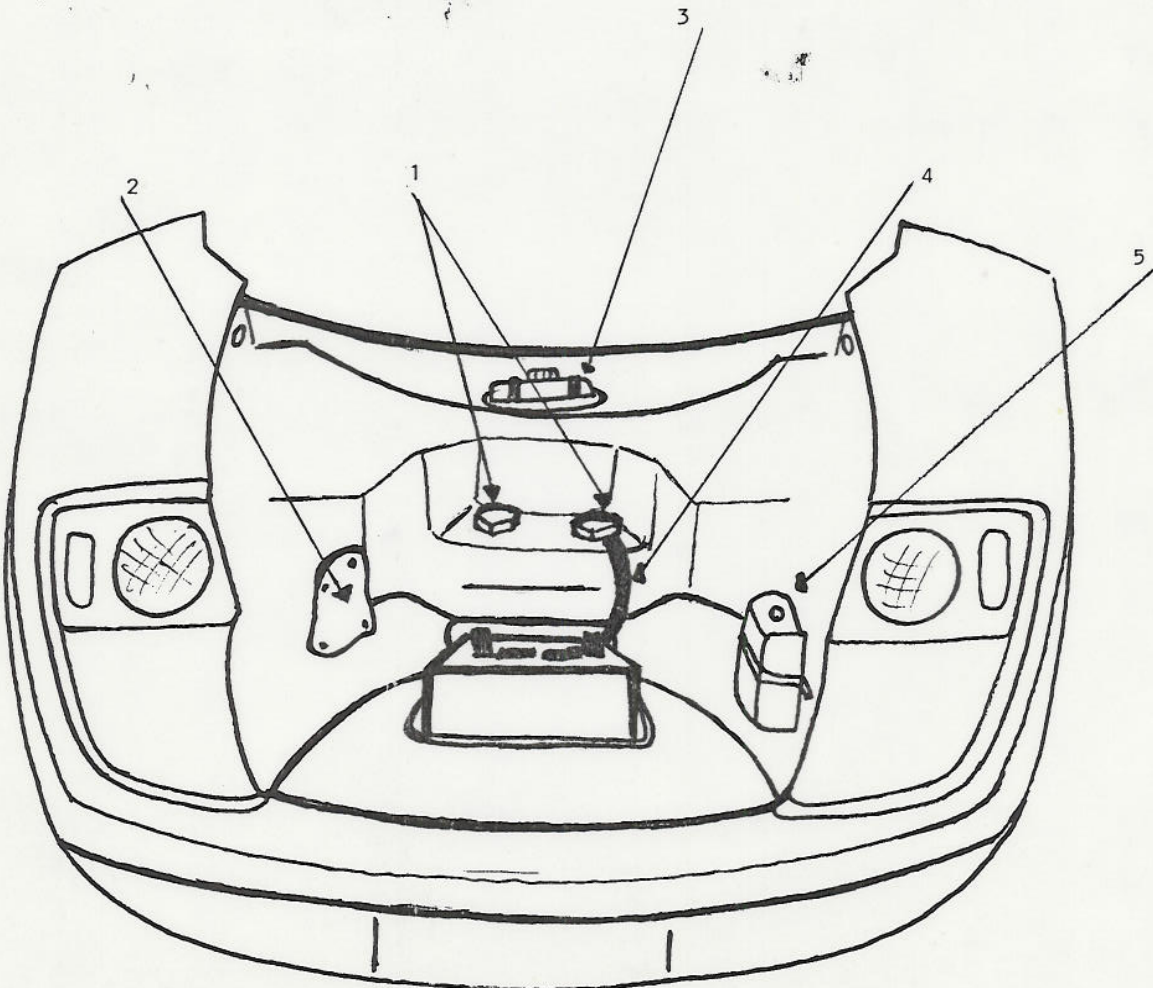

ROOF LIFTING GEAR ASSEMBLY:

Turn roof upside down and drill holes using bracket as template. Bolt bracket to roof. Position roof on body and drill through side plate then bolt in position. Lift the roof and prop in place. Drill remaining holes and bolt together.

For hardware see bag marked ROOF LIFT.

ADJUSTING THE TOP OF YOUR EUREKA:

- A. Remove interior side panels (if they are installed) exposing a stud and nut on the hinge assembly. It's the one with the slotted hole.
- B. While in the car with a 9/16" socket/ratchet, loosen both the left and right side and then have someone close the top completely down and latched at the back. Have a couple of mate's hold the two front corners of the top down with their full weight.
- C. While top is held down in this manner tighten the left one tight, then do the right side tight. Both tight, adjustment complete.

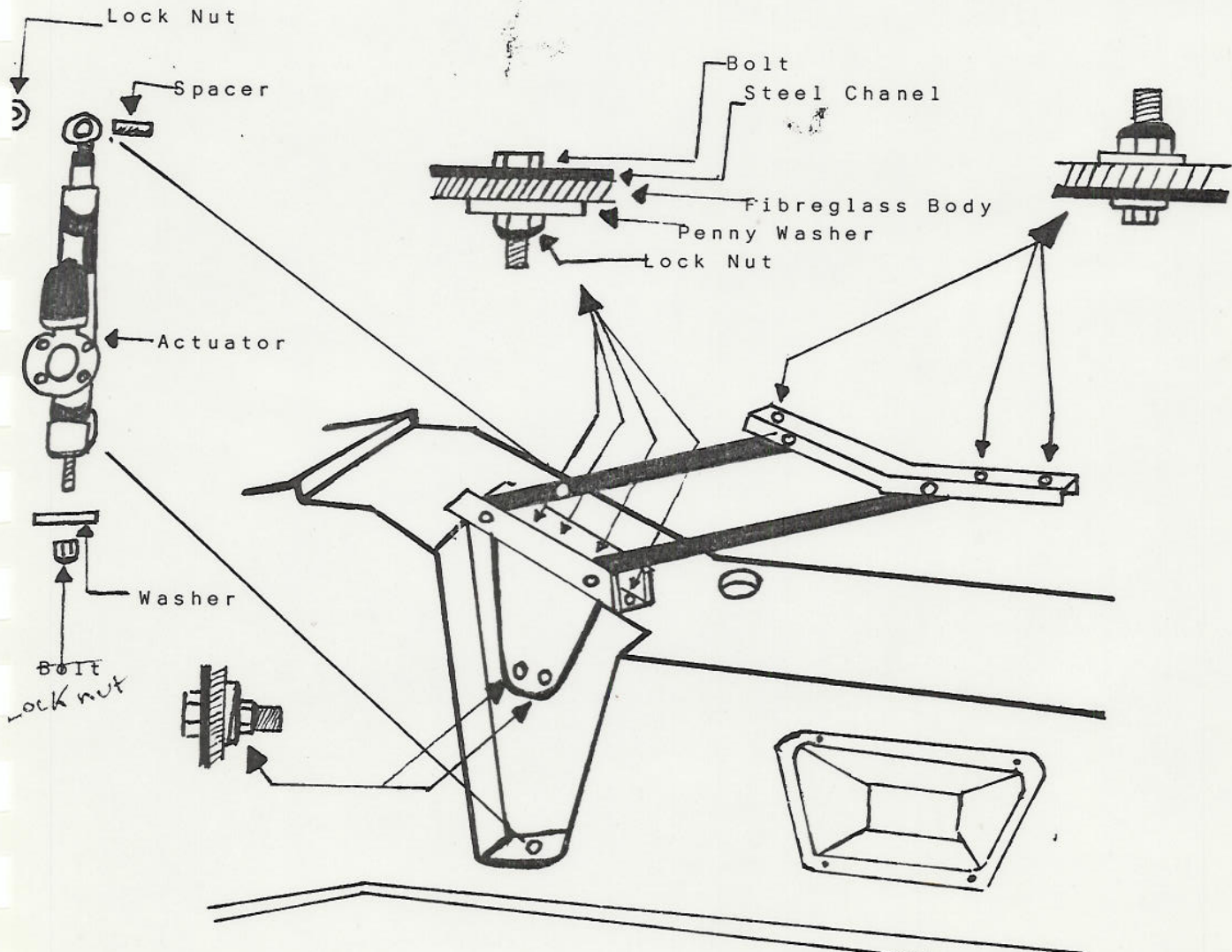

N.B. An adjustment to the top may be required from time to time, if you travel rough roads as vibration may work nut on hinge loose, causing adjustment to change.

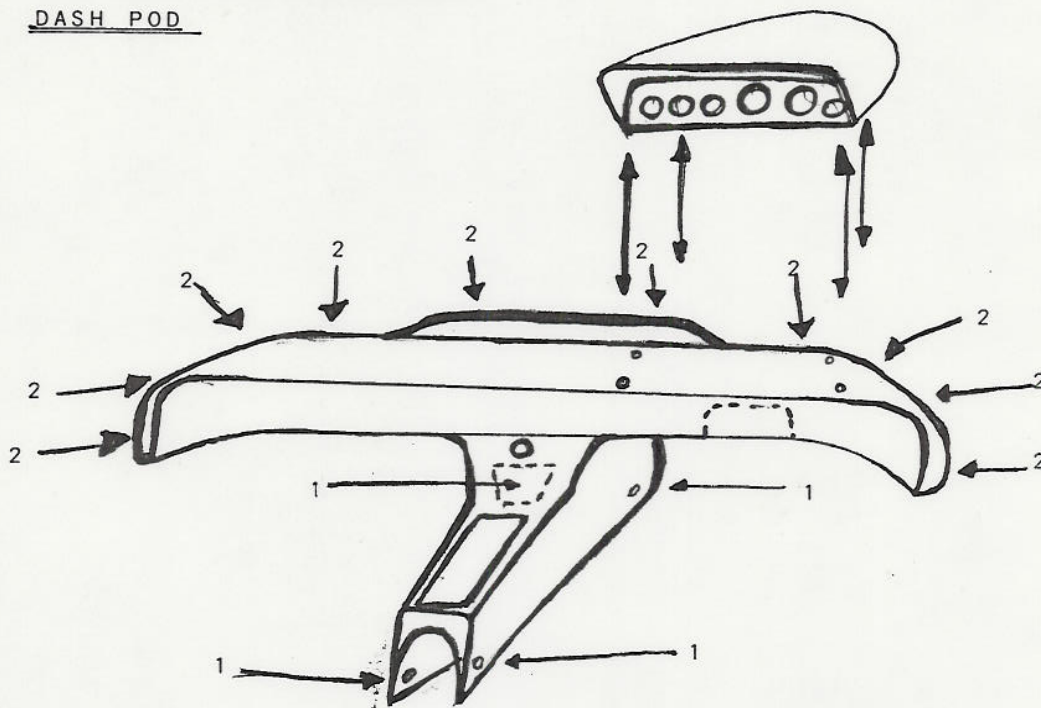
DASH AND CENTRE CONSOLEDASH POD

Place the dash into position and cut the appropriately positioned gear lever hole.

It is advisable to cut a big enough hole so that the gear lever assembly can be removed through it if necessary. With the dash in position, climb inside the car & close the roof.

This will enable you to position the dash accurately. Make sure there is an even gap approximately $\frac{1}{2}$ " between the dash and the bottom of the windscreen. Bolt the dash in using $\frac{1}{2}$ " bolts and large washers.

1. Use self tapping screws through centre console into tunnel. (two on each side)
2. Bolt dash to body points.

STEERING COLUMN:

1. Dash Pod
2. Collapsible Type Steering Column
3. Steering Box
4. Rubber Grommet Through Body
5. Clamp for alignment of steering box.
6. Column to dash bracket to be bolted
7. Location for fuse to be clamped on steering column

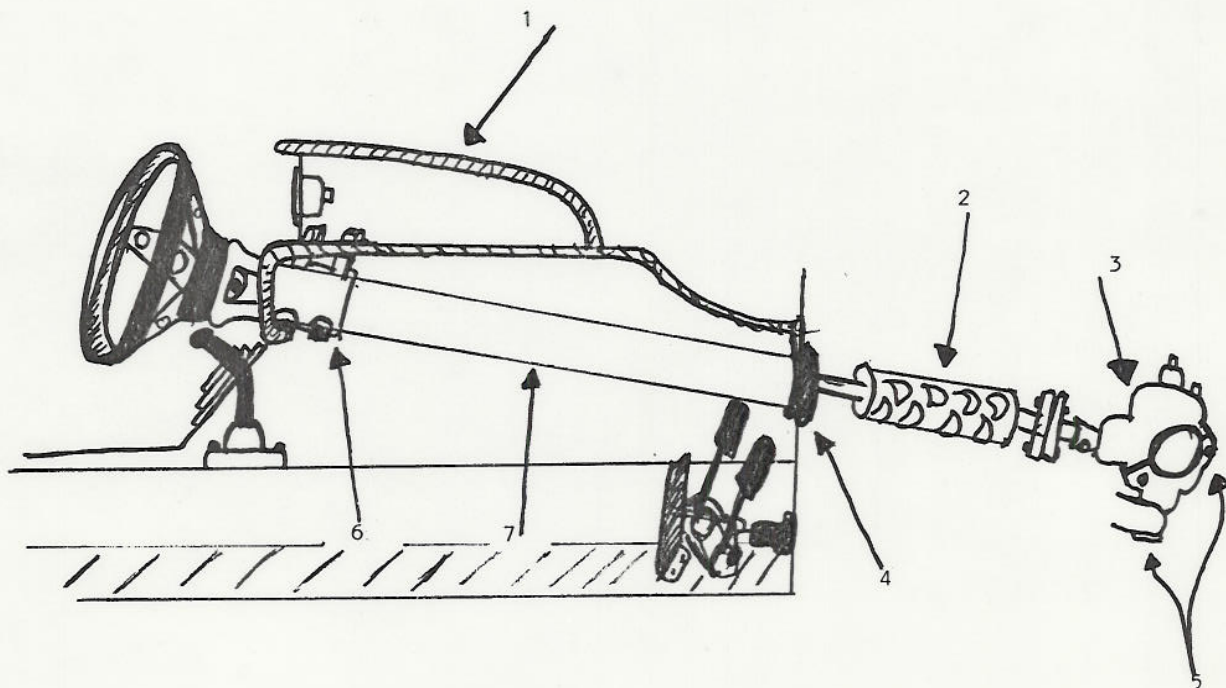

1. We suggest using a "T" made of P.V.C. used commonly in plumbing. A 2" of "T" will have approximately a 3" O.D. for the ducting to fit over.
2. "T" shaped P.V.C.
3. Blower Fan. (ex Combi)
4. Fibreglass P.V.C. to the blower fan.
5. Blower fan mounted under dash.
6. Heater & fresh air tubes are installed inside inner body.
7. Air must flow through into engine compartment.
8. Fresh air

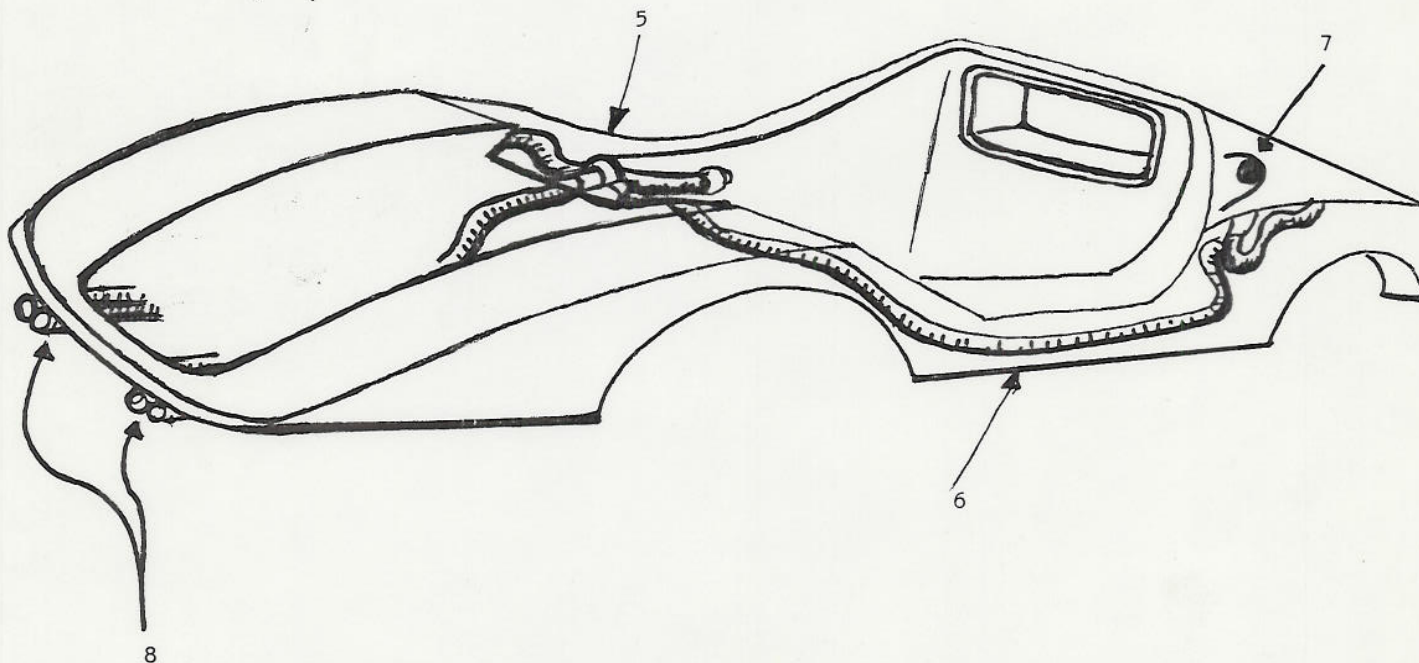
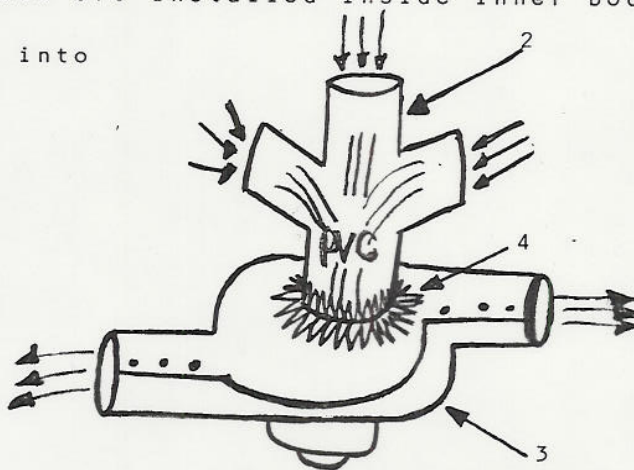

DUCTING AND HEATER INSTALLATION:

Ducting & Heater - defroster, fresh air vents.
 See below for routing. Heater tubes are installed inside inner body. Route heater ducting through the side panels & attach to the V.W. heater boxes on one end & at heater vents as shown. We suggest that the hose (defrost) be installed through body & dash as high as possible above heater vents to avoid interference with your feet.

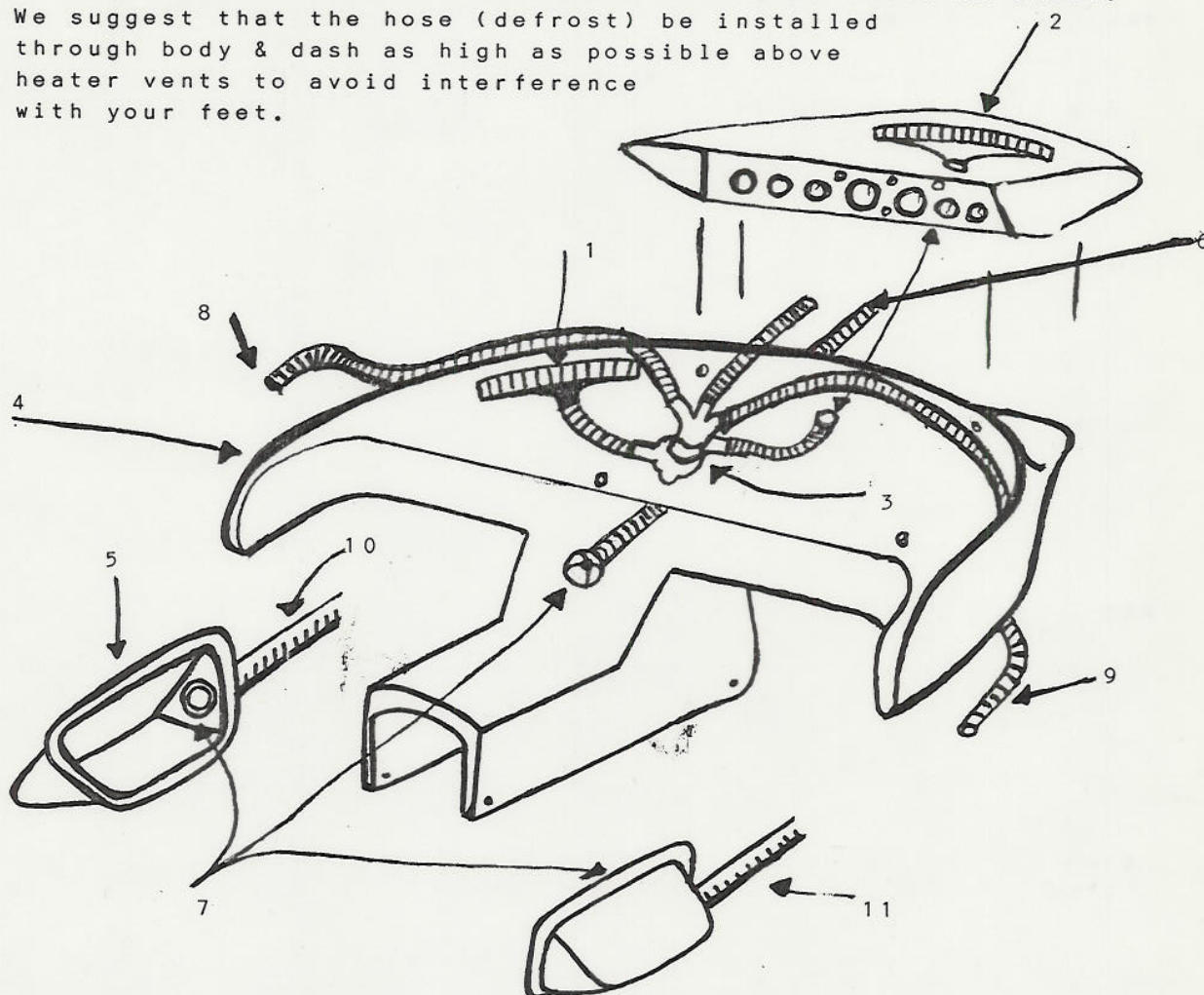

1. Dash demister vent
2. Dash Pod demister vent
3. Blower Fan
4. Dashboard Assembly
5. Side Pocket
6. Fresh cold air tube
7. Fresh cold air vent
8. Passenger side heated air intake [direct from stock
9. Driver side heated air intake V.W. heater boxes]
10. Passenger side fresh air intake [direct from front
11. Driver side fresh air intake opening in nose]

1. Cut opening in each of these scallops. Place screen of steel fly mesh (paint black) behind each intake.
2. Use bolt, flat washer. lock washer, nut and body washer combination to bolt rear of front undersil to the floor pan.
3. Bolts used on side of front undersil section are type "C" combination, same as used on side panels. Some pressure or effort may be required to align lower panel with edges of upper main body.
4. Nose section of main body.
5. Under nose section.
6. Self tapping screw washer- See type A bolt combination.
7. 1" (one inch) hole at this point. (So that you will have access for a socket).
8. A 3/8" hole through this flange so that shank of self tapping screw will pass through.
9. A 1/8" hole through this flange so that self tapping screw may be threaded into fibreglass flange.

Suggestion:

For final touch, mask off around perimeter of opening in nose and spray the entire recessed area black taking care to make a clean mask.

1. Fasten this panel at area shown using bolt, flat washer, lock washer & nut.
2. Using alloy sheet, cut the necessary shape & fasten to the body panels to cover the gaps.
3. Opening in scoop for fresh air supply to rear brakes. (back with fine steel mesh & paint black).
4. File the edge of the inner wheel arches to form a matching curve.
- 5a Main Body.
- 5b. Lower side panel. (don't be afraid to push or pull when aligning, as fibreglass does not crack or break easily).
6. V.W. floor pan.
7. Belly pan gasket. Be sure to put the silicone on as mentioned in "Construction of the Car"
8. Access for working on interior bolts is gained through the side pocket openings.
9. Fix undersil panel to the floor pan with nuts, bolts & large square steel washers.

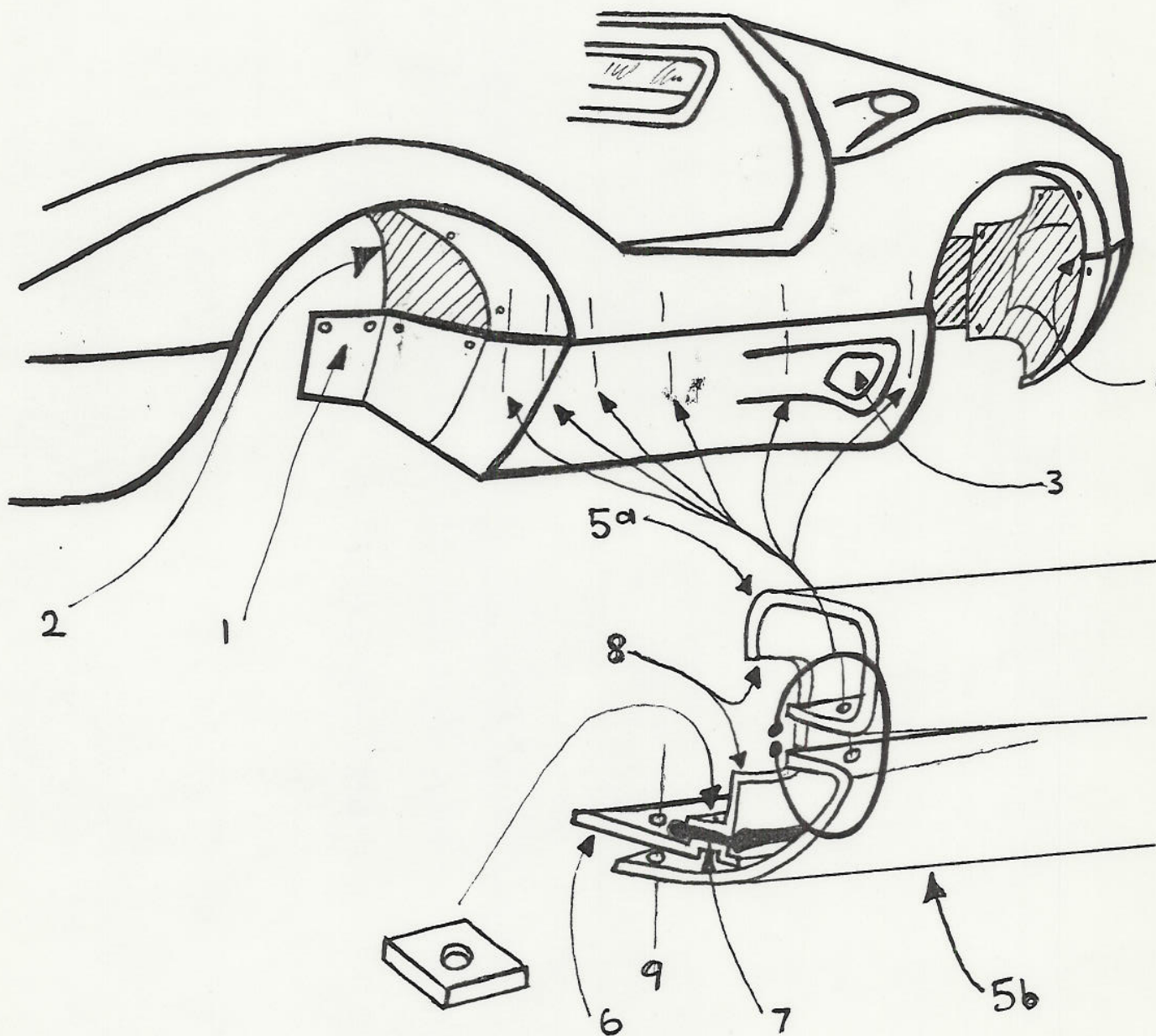

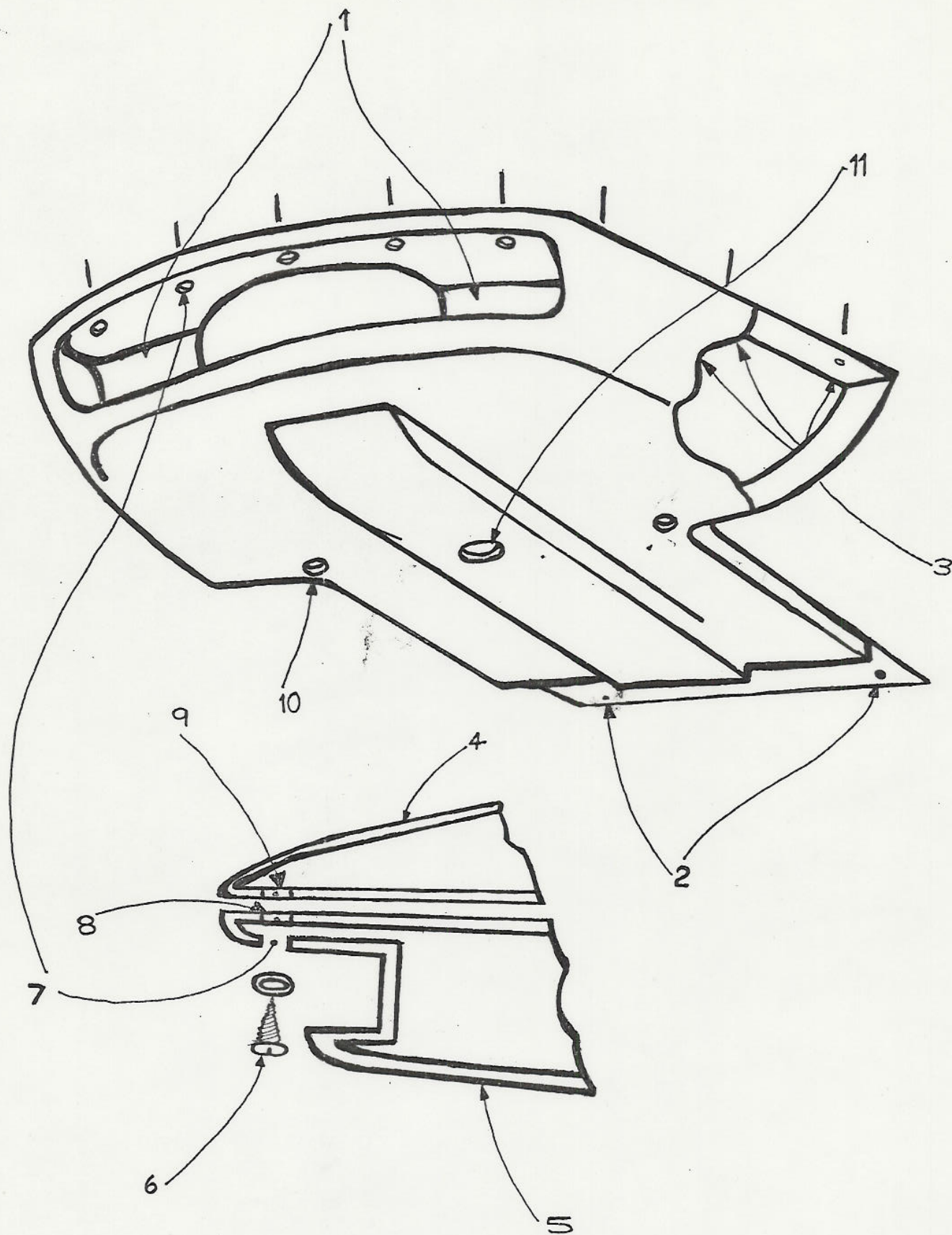

1. Floor Pan
2. Body to Floor Pan Bolts
3. Notch already cut in body for brake line.
4. Chassis Number cut out. (already completed)
5. Access hole for removal of Trans-axle. (if ever need to)
6. Attaching points for Rear Undersil.

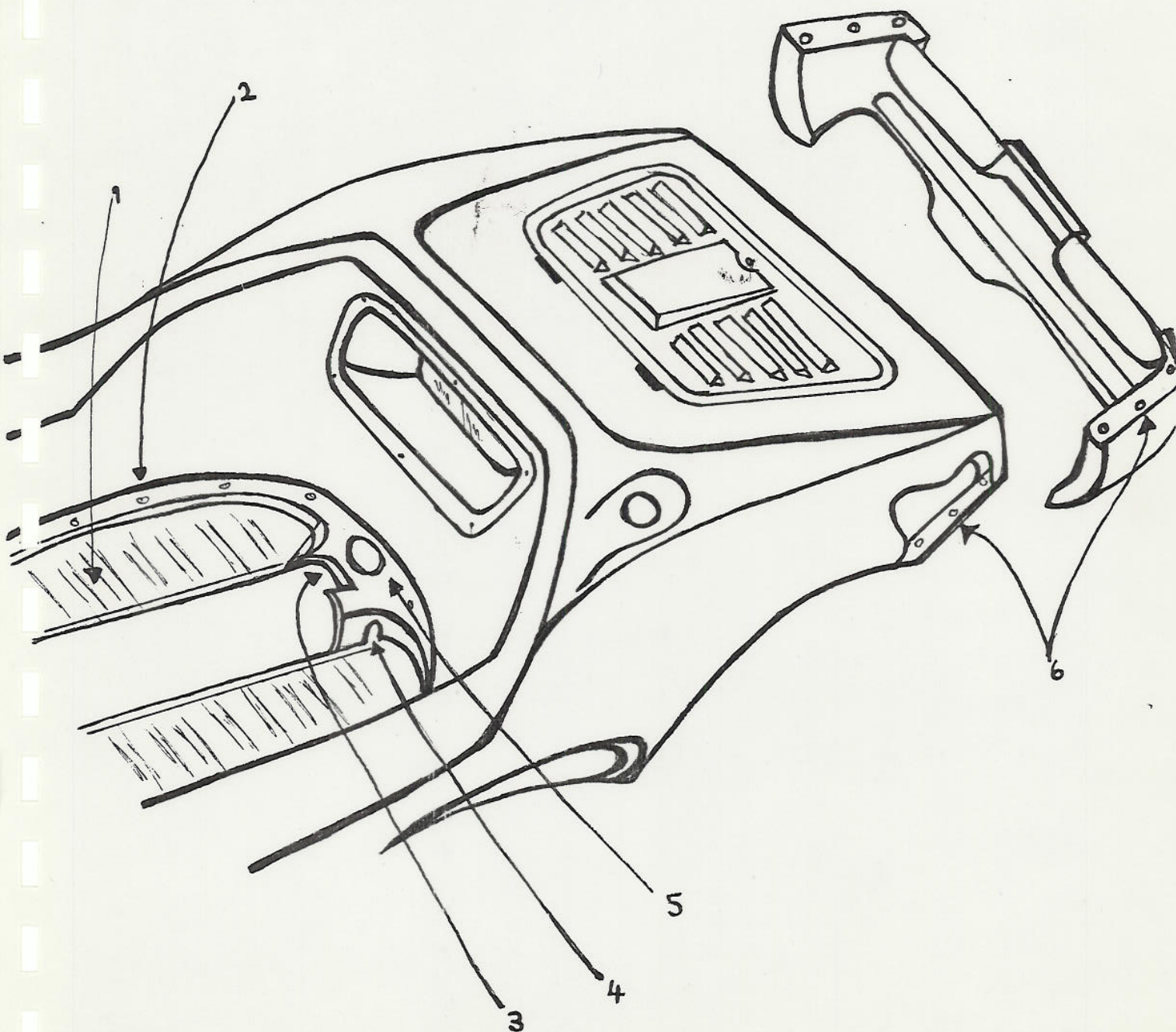

SEATS:

From the original Volkswagon seats, cut the runners and adjusters. Thoroughly clean and sand the runners. Weld the 18" cross members in between the seat runners and drill holes for bolts for securing seat using seat insert plates. Bolt to floor pan using floor pan plates under floor pan.

1. Seat Insert Plates
2. Floor Pan Plates
3. Cross Members welded between Seat Runners.
4. Floor Pan.
5. Seat

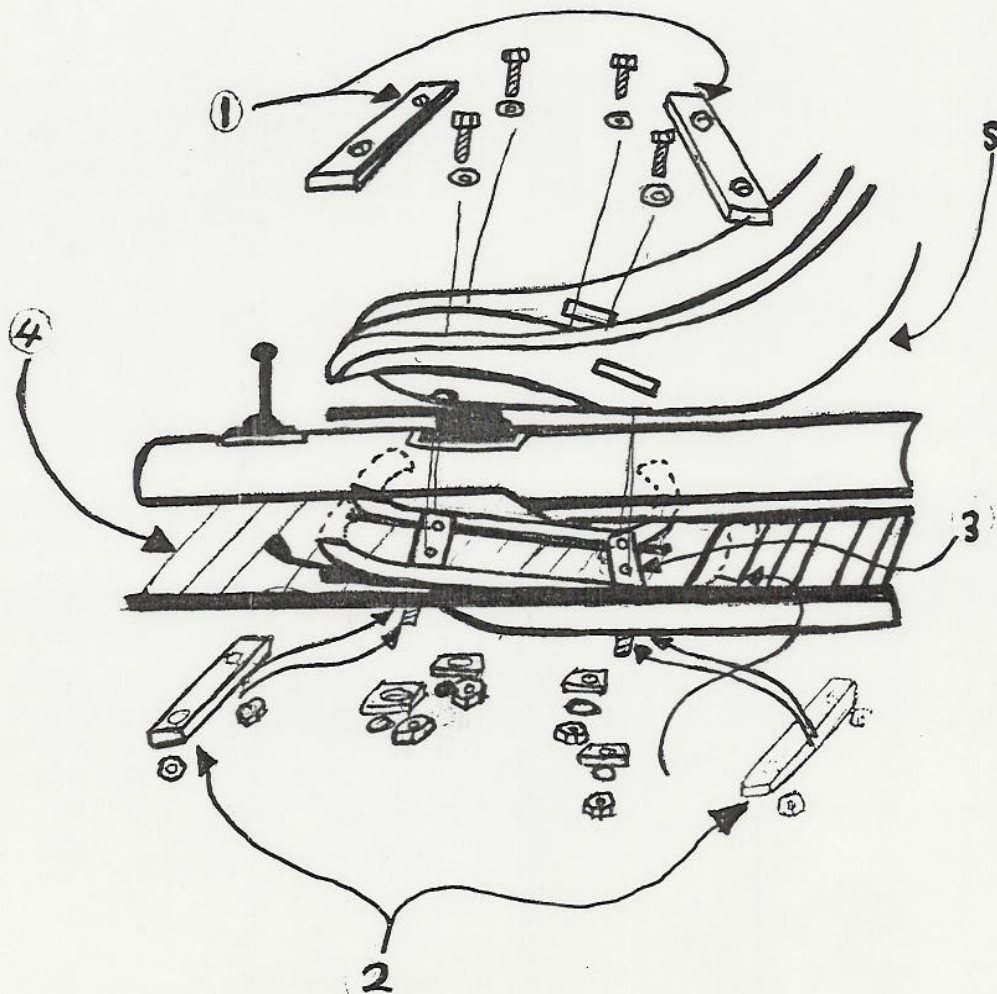

Alternative using seat runners from
other donor vehicles.

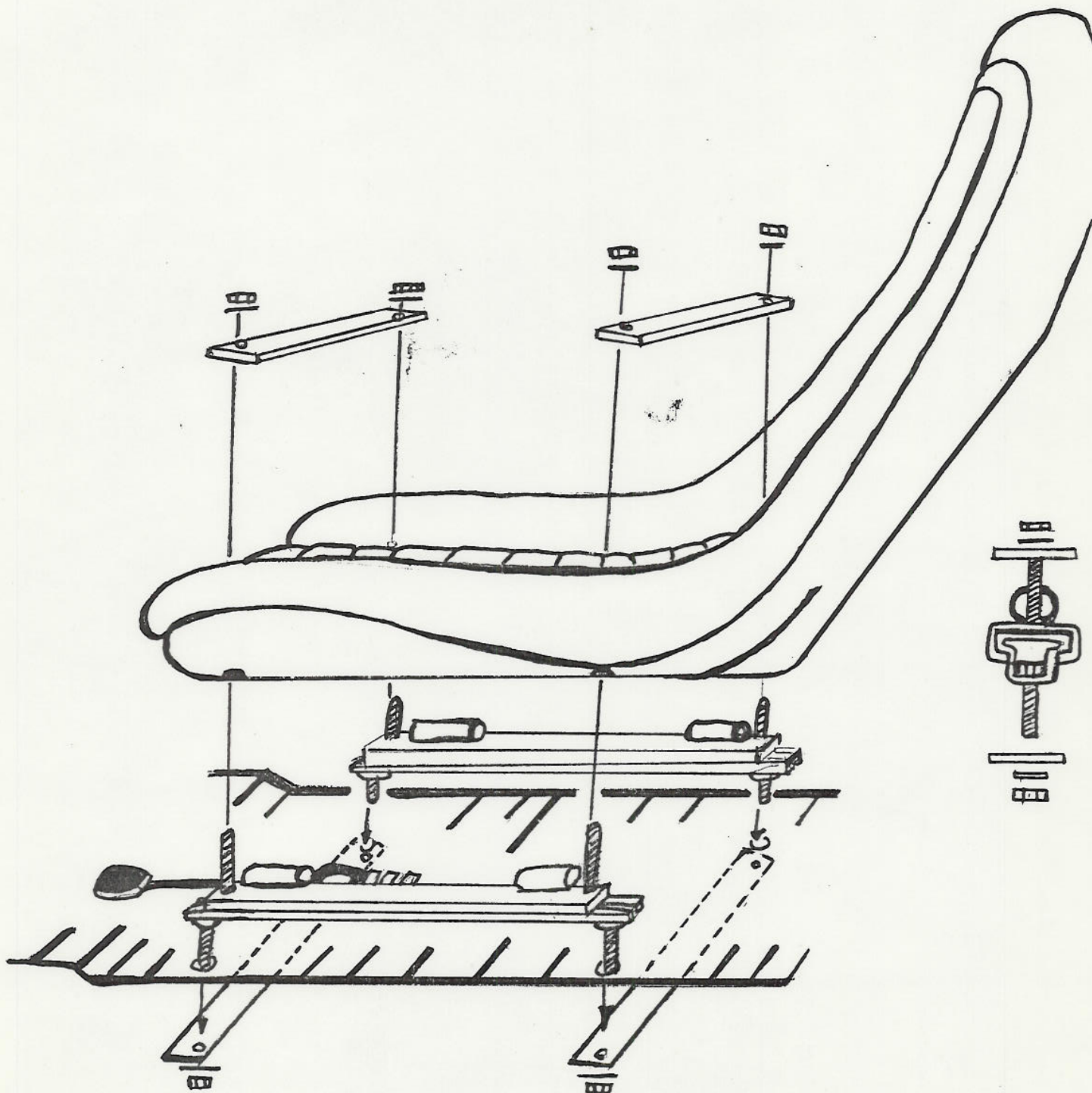
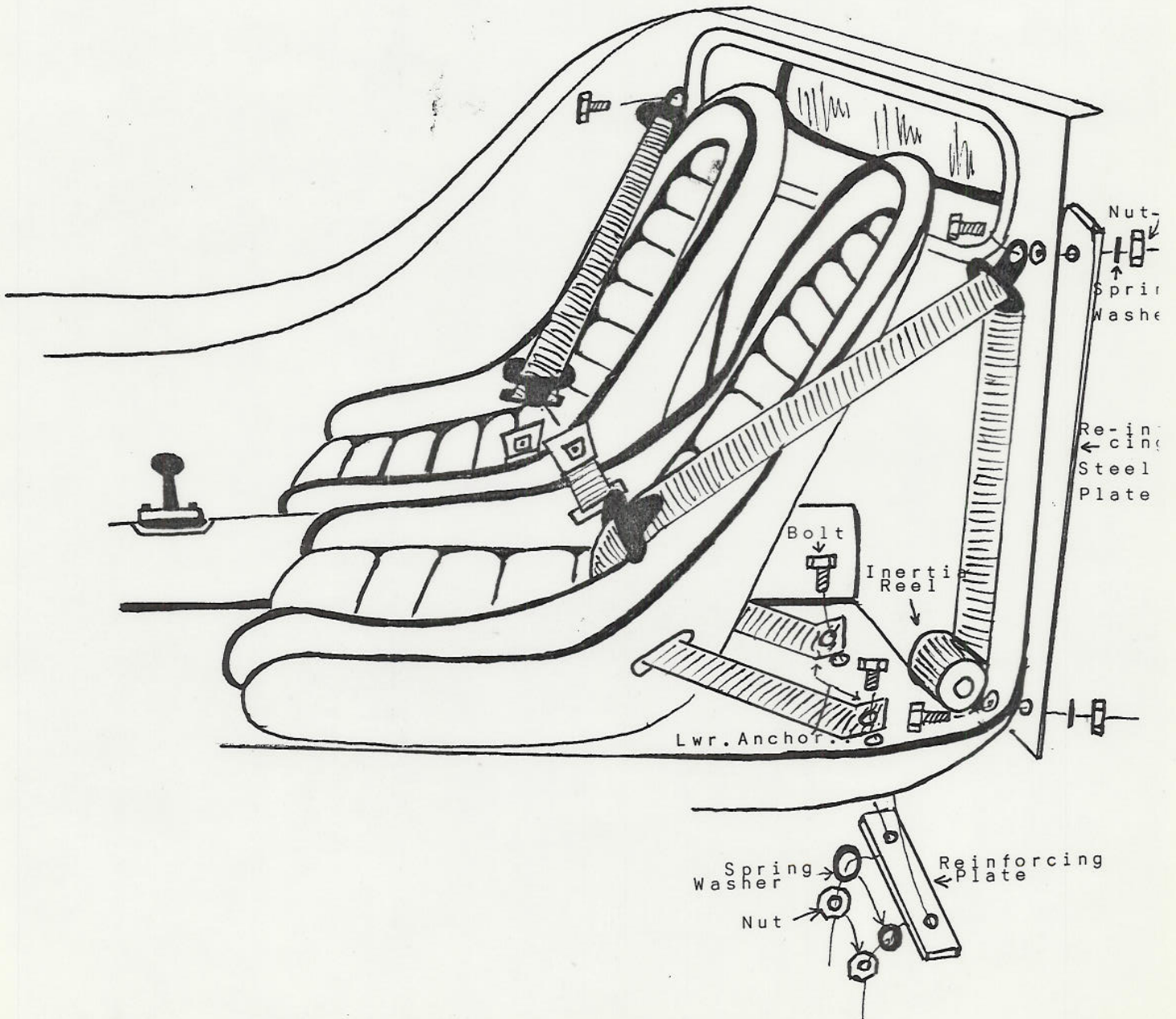
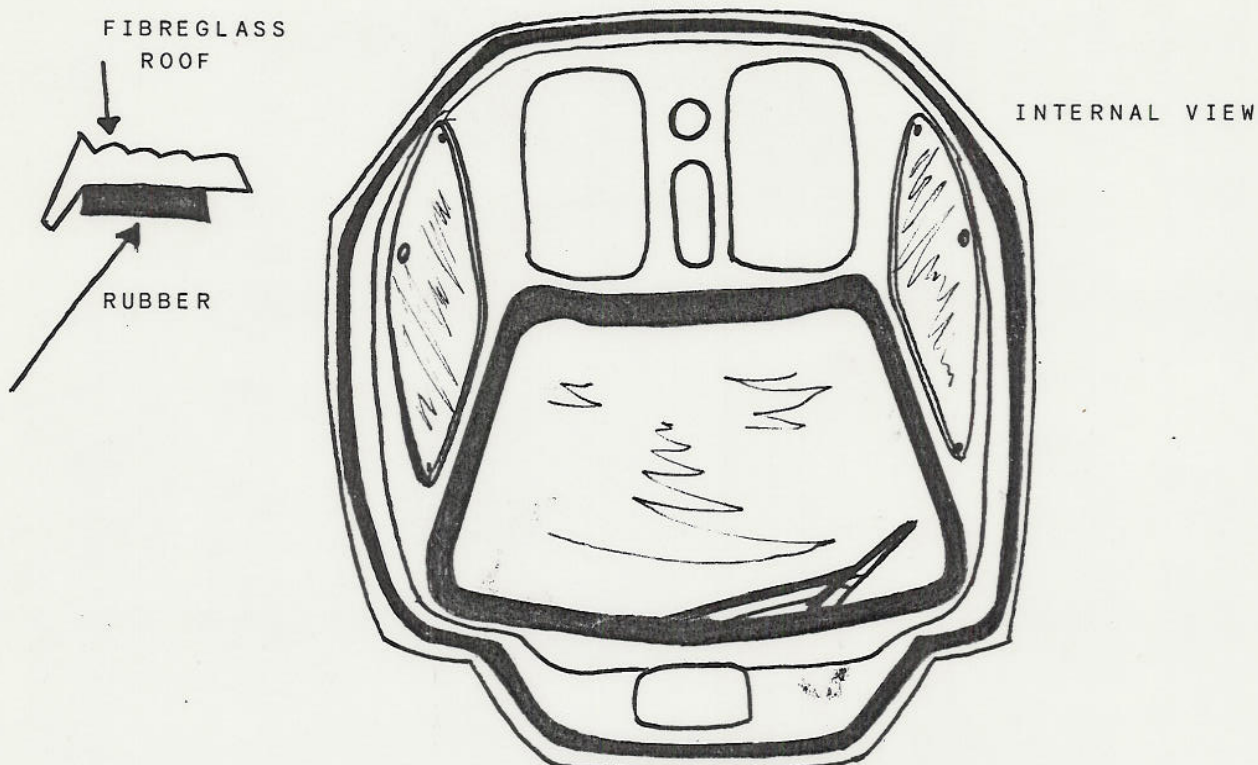

Diagram depicting the positioning of the Inertia Reel Seat Belt System.

You must comply with this otherwise Registration of your car will be very difficult.



ROOF SEALING RUBBER

Glue rubber sealing rubber with contact adhesive.

CARE & FEEDING YOUR EUREKA

1. Keep it clean "Exterior"
 - A. Wash with water. Chamois completely.
 - B. Road tar or scum may be removed by using tar & grease remover or paint thinner for stubborn areas.
 - C. We recommend K&H Polylustre Sealer & Reseal Glaze for the protection of the gel coated finish.
2. Keep it clean "Interior"
 - A. Seat Upholstery-Clean with small amount of soap and water, damp cloth only, then wipe with clean damp cloth.
 - B. For show type finish on upholstery, spray on Armor-All and wipe with clean dry cloth. This works on all interior black parts i.e. dash etc.
3. Heat from exhaust will burn off paint on exhaust system & is seen from the rear. Spray it with heat resistant black paint (spray can) from time to time makes things look cleaner.

WIRING: (Contact your nearest Auto Electrician)

The battery should be disconnected while you are in the process of wiring. After you are all done, turn everything off & hook up ground cable to battery. Just touch the positive cable (with #10 red wire attached) to positive terminal of battery. There should be no spark at all. If there is, check again to be sure everything is turned off. If the spark still occurs, try pulling one fuse at a time to see which circuit has a problem. If there is no spark, hook the positive cable to the battery and then check all functions for operation. Remember, for everything to operate, the circuit must be complete.

N.B. All electrical equipment must be grounded as fibreglass will not conduct electricity. All grounds are black in harness and all grounds are supplied for equipment standard in kit.

In order to place the battery in the front, you must obtain approx 13 ft. of battery cable & route down left side of car, strapped to edge of floor pan inside left panel area to the starter motor at the rear. It must be remembered that you must ground each elec. item independently. For access, the regulator needs to be positioned in the eng. compartment & fastened to the inner wheel arch.

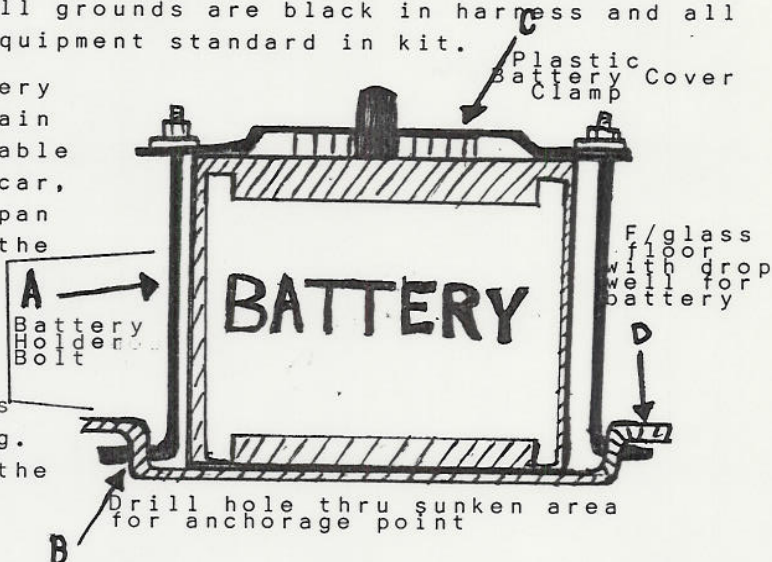
CAUTION:

Battery cover must be used to prevent a possible short between battery terminals and spare wheel. Alternative would be to use a '68 HK Holden battery tray. Simply bolt to floor. (use for normal battery size)

NOTE: If you would like the ultimate in electrical protection, a battery switch can be installed (boat supplier) If you install the switch, not only the battery cable but the hot wire (#10 Ga) going into the fuse box must go thru switch. This switch shuts off all elec. to the car. It makes a good anti theft device.

1. Partial view of upright VW engine as viewed from rear.

2. Approx location for oil temp sender. Drill & tap for sender unit using 29/64 drill & 1/8" SAE UNF tap. (do this while engine is full of oil so that chips of metal will be flushed out)

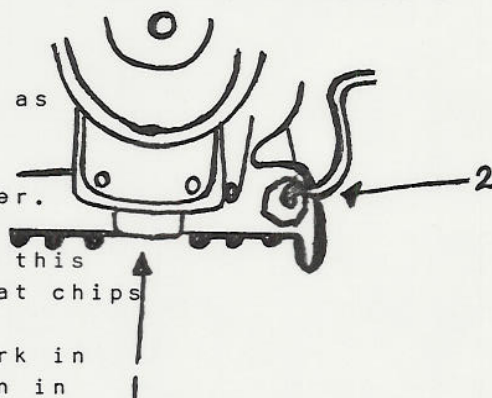

Warning: VW sending unit will not work in oil drain plug hole as shown in manufacturers instructions as it plugs up oil pick up tube.

FUEL TANK SENDER:

VW sender unit may not be compatible with fuel gauge so use new sender supplied. Simply remove the VW unit & replace with new unit. Bend the arm so that a full reading is given when tank is full.

INTERIM HEADLIGHT SET UP

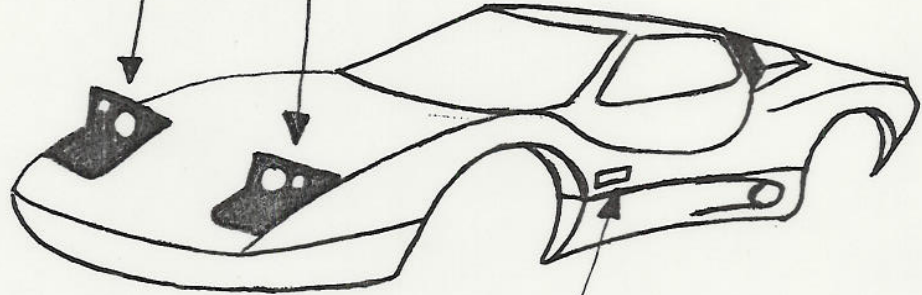

SIDE FLASHER LOCATION

STEEL STRENGTHENING CHANEL

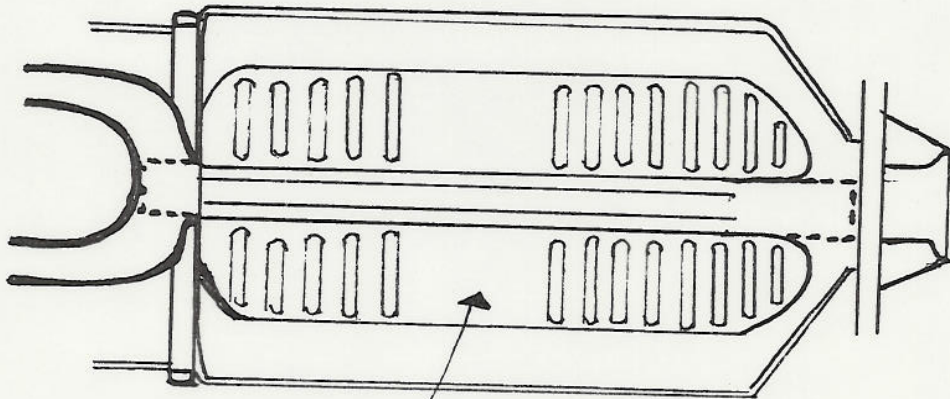
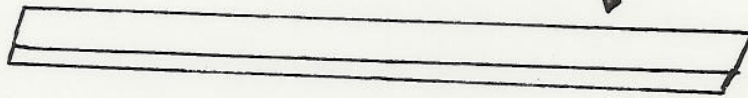

TACK WELDED UNDER FLOOR PAN

THIS BOOK HAS BEEN COLLATED AS A BASIC GUIDE TO BUILDING YOUR EUREKA. YOU MAY WISH TO DO THINGS IN A DIFFERENT SEQUENCE, THIS IS FINE SO LONG AS YOU FOLLOW THE BASIC'S.

FROM TIME TO TIME A CUSTOMER WILL COME UP WITH AN IDEA OR SUGGESTION THAT REALLY WORKS. WE HAVE, AND WILL CONTINUE TO MAKE THESE TIPS OR IDEAS AVAILABLE TO OUR CUSTOMERS.

These instructions do not give details or information on how to do optional or extra things you might want to do to your EUREKA, but don't be reluctant to try, as it is these little ideas of yours that set your EUREKA apart from the others. If you care to bounce your ideas off on someone, feel free to call upon us because we talk to other EUREKA owners daily and based on their experience and ours, we may be able to save you from mistakes already made by some other builder.

EUREKATHE CAR FOR THE INDIVIDUAL.....EUREKA

A book that could be quite handy for you:

"HOW TO KEEP YOUR VOLKSWAGON ALIVE"

By John Muir

COMPREHENSIVE KIT:
PARTS CHECK LIST

- 1...MAIN BODY FIBREGLASS SHELL (including petrol tank support)
- 1...ROOF INNER & OUTER SKIN (bonded together)
- 1...FRONT UNDERSIL
- 1...REAR UNDERSIL
- 1...DRIVER SIDE UNDERSIL
- 1...PASSENGER SIDE UNDERSIL
- 1...FRONT BONNET
- 1...ENGINE COVER LID
- 2...SIDE SHOULDER TRIM
- 2...SIDE POCKET
- 1...DASHBOARD ASSEMBLY
- 1...DASH INSTRUMENT POD
- 2...HEADLIGHT BOX
- 2...REAR SUSPENSION MOUNT
- 1...REAR WINDOW TUNNEL INSERT
- 1...LAMINATED WINDSCREEN (install. with)
- 1...WINDSCREEN MOULD SURROUND
- 2...SEAT SHELLS
- 2...FULL UPHOLSTRY TRIM TO ABOVE SEAT SHELLS
- 1...REAR BLADE (over rear window)
- 2...ELECTRIC ROOF LIFT ACTUATOR
- 2...INSTALLATION KIT (fitted to actuator)
- 1...INSTRUCTION LEAFLET (for electric roof lift assembly)
- 1...INTERNAL TOGGLE SWITCH
- 1...EXTERNAL KEYED SWITCH
- 2...UNIVERSAL ROD END
- 2...SWITCHING RELAY
- 16...NYLON BUSH
- 1...SET ROOF LIFT BRACKET ASSEMBLY (8 pieces)
- 8m...ROOF SEALING RUBBER
- 3m...SIDE WINDOW RUBBER (upper)
- 2...STRIPS SIDE WINDOW RUBBER (lower)
- 1.8m...REAR WINDOW RUBBER
- 1...REAR WINDOW (POLYCARBONATE)
- 1...SPORTS STEERING WHEEL
- 1...BOSS
- 2...SIDE WINDOW (POLYCARBONATE)
- 2...SIDE WINDOW LOCK CATCH
- 2...SIDE WINDOW CHROME SCREW
- 2...SIDE WINDOW BLACK RUBBER WASHER
- 2...SIDE WINDOW CHROME BUTTON
- 4...SNAP CAP
- 2...HELLA SEALED BEAM HEADLIGHT
- 2...HEADLIGHT PLATE
- 2...HEADLIGHT RIM
- 6...HEADLIGHT SCREW
- 6...HEADLIGHT NUT
- 2...FRONT FLASHER
- 2...SIDE FLASHER
- 2...TAIL LIGHT STOP
- 2...TAIL LIGHT AMBER
- 1...REVERSE LIGHT
- 1...NUMBER PLATE LIGHT

* ASSEMBLE INSTRUCTION MANUAL

HARDWAREBODY TO FLOOR PAN

18 ...0057-10-40 BOLTS
 18....0317-010 NUTS
 18....441-010 SPRING WASHERS
 18....ES-0050 FLAT SQUARE STEEL WASHER

ROOF LIFT ASSEMBLY KIT

16....00578.30 CHANNEL BOLT
 16...,)0368 CHANNEL NUT
 16....411 10 30 CHANNEL WASHER
 8....007238212 LIFTING TUBE BOLT
 8....0373 38 LIFTING TUBE NUT

LOWER PANELS

22...057625 BOLT
 22...603686 NUT
 44...407 8 FLAT WASHER

DASH ASSEMBLY TO BODY

6....057625 BOLT
 6....3686 NUT
 12...407.8 FLAT WASHER

INSTRUMENT POD TO DASH ASSEMBLY

4....00578.30 BOLT
 4....368.8 NUT
 4....407.8 WASHER

FRONT BONNET

2....8201286350 RAWLNUT
 2....0057.6.40 RAWLNUT BOLT
 2....ES1250 LOCK & KEY

ENGINE COVER LID

2....ES0245 HINGE-SCREW-NUT
 1....ES1250 LOCK & KEY

- 1...WINDSCREEN WIPER KIT ASSEMBLY COMPLETE
- 2...AIR FLOW LOUVRE
- 1...VOXON BLACK PACK RADIO INCLUDING SPEAKERS
- 1...ROOF AERIAL
- 1...VDO SPEEDO
- 1...VDO VOLT
- 1...VDO FUEL
- 1...VDO TACHO
- 1...VDO OIL PRESSURE
- 1...VDO OIL TEMPERATURE
- 1...WOODGRAIN FASCIA PANEL (above instruments fitted complete with
- 1...OIL PRESSURE SENDER (warning lights)
- 1...OIL TEMPERATURE SENDER
- 1...WIRING LOOM COMPLETE
- 2...SEAT BELT (Lap Sash)
- 1...INTERNAL REAR VIEW MIRROR
- 1...EXTERNAL REAR VIEW MIRROR
- 1...CARPET SET (Including Side Walls)
- 1...FIRE EXTINGUISHER
- 2m..AUTO FLEX 3"
- 7½m.PAPER DUCTING 2½"
- 1...INTERIOR LIGHT
- 2...EXTRACTOR
- 2...MUFFLER
- 2...TIP CHROME
- 4...RANGER RV MAG (Other type available optional extra)
- 4...TYRE TO SUIT (Other tyre available optional extra)
- 1...EUREKA DECAL (BADGE IDENTIFICATION OPTIONAL)
- 1...WINDSCREEN WASHER BOTTLE
- 1...HAZARD WARNING LIGHT KIT

.....

OPTIONAL

- AIR INTAKE BOXES (2 STYLES)
- REAR WING (LAMBO STYLE OR LOWLINE STYLE)
- HEADLIGHT COVERS
- T-TOP TARGA ROOF COMPLETE
- BULGE STYLE BONNET
- EUREKA T-SHIRTS
- EUREKA CAPS
- LAPEL BADGES
- EUREKA IDENTIFICATION BADGE
- EUREKA NOSE BADGE SHIELD
- EUREKA KEY SCRATCH PROTECTOR
- EUREKA HORN BUTTON BADGE
- EUREKA GEAR KNOB BADGE

A Guide To Build Sequence

- 1 REMOVAL OF THE V.W. BODY
- 2 PREPARE & REFURBISH CHASSIS & FLOOR PAN
- 3 WELD STEEL CHANEL UNDER FLOOR PAN
- 4 FIT PETROL TANK TO EUREKA BODY
- 5 FIT FIRE WALL
- 6 FIT NOISE REDUCTION BOX
- 7 FIT BELLY PAN GASKET TO CHASSIS
- 8 TRIM EUREKA BODY
- 9 BOLT BODY TO CHASSIS
- 10 FIT REAR SUSPENSION MOUNTS
- 11 FIT FRONT SUSPENSION MOUNTS
- 12 FILL GAPS BETWEEN BODY & CHASSIS
- 13 FIT ROOF LIFT BRACKETS ASSEMBLY
- 14 FIT DASH CONSOLE & DASH POD
- 15 FIT STEERING COLUMN
- 16 FIT SIDE UNDERSILS
- 17 FIT FRONT UNDERSIL
- 18 FIT REAR UNDERSIL
- 19 FIT HEATER TUBES
- 20 FIT HEATER BLOWER FAN
- 21 FIT FRONT HEADLIGHTS
- 22 FIT REAR LIGHTS
- 23 FIT ROOF
- 24 FIT WIPER ASSEMBLY
- 25 FIT FRONT FLASHER
- 26 FIT BATTERY
- 27 FIT WIRING LOOM
- 28 FIT REVERSE LIGHT
- 29 FIT NUMBER PLATE LIGHT
- 30 FIT RADIO AERIAL
- 31 FIT INTERIOR LIGHT
- 32 FIT DASH SWITCHES
- 33 FIT RADIO CASSETTE PLAYER
- 34 FIT REAR VISION MIRRORS
- 35 FIT CARPET KIT
- 36 FIT SIDE POCKETS
- 37 FIT REAR WINDOW
- 38 FIT REAR WINDOW TUNNEL
- 39 FIT SEAT BELTS
- 40 FIT ENGINE COVER LID
- 41 FIT FRONT BONNET
- 42 FIT SIDE SHOULDER TRIMS
- 43 FIT SIDE WINDOWS
- 44 FIT WINDSCREEN WASHER BOTTLE (Laminated Screen Fitted Ex Factory)
- 45 FIT SPEEDO CABLE
- 46 FIT HAND BRAKE
- 47 FIT SEATS
- 48 FIT STEERING WHEEL
- 49 FIT FIRE EXTINGUISHER
- 50 FIT ROOF SEALING RUBBER
- 51 FIT WHEEL ARCH TINWARE (To finish off)